



 **ENQUIP**®

GHL2025

**2.500 KGF
(5,500 LBF)**

GUINCHO HIDRÁULICO DE LEVANTAMENTO HYDRAULIC HOIST WINCH

CARACTERÍSTICAS FEATURES

- Freio multi-discos, normalmente aplicado por molas, liberado por pressão hidráulica. Confere ao guincho a capacidade de frear a carga mesmo ocorrendo falha hidráulica. Freio em conjunto com embreagem uni-direcional anti-recuo.
- Redutor planetário altamente compacto, montado internamente ao tambor, composto por engrenagens em aço ligado tratadas termicamente, conferindo elevada vida útil ao equipamento.
- Motor hidráulico orbital de alta eficiência.
- Válvula de frenagem dinâmica, de contrabalanço, permite uma operação suave e controle preciso da carga.
- Tambor montado sob rolamentos de alto desempenho, maximizando a eficiência.
- Peso Bruto (Sem Cabo de Aço): 50 Kgf.
- Multi-disc brake, normally applied by spring, hydraulically released. Gives to the winch brake capacity even under hydraulic failure. Brake mounted with one-direction overriding clutch.
- Compact planetary gear reducer, mounted inside the drum, compound by alloy steel gears, heat treated, giving to the equipment a higher life cycle.
- High efficiency hydraulic geroler motor.
- Dynamic, counterbalance braking valve allows for smooth operation and precise load control.
- Drum mounted over high performance anti-friction bearings used to maximize efficiency.
- Gross Weight (W/O Wire Rope): 110 LB



DIMENSÕES EM MILÍMETROS
DIMENSIONS IN MILLIMETERS

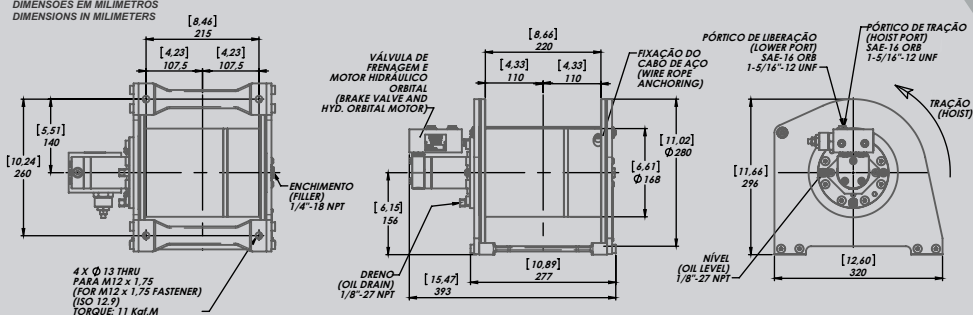

Copyright 2023 - ENQUIP
All Rights Reserved



DESEMPENHO POR CAMADA PERFORMANCE BY LAYER

GHL2025-A-33/OR11

20 cc Motor Hidráulico (Hydraulic Motor) (1,2 ci)
160 bar (2.320 PSI) @ 30 lpm (8 gpm)
Diâm. Cabo (Wire Rope Diameter): 11 mm (7/16")

	TRAÇÃO LINE PULL		VEL. LINHA LINE SPEED	
	KGF	LBF	M/MIN.	FT/MIN.
1	1.389	3,062	25,0	81.9
2	1.237	2,727	28,0	92.0
3	1.115	2,458	31,1	102.1
4	1.015	2,237	34,2	112.1

GHL2025-A-33/OR12

32 cc Motor Hidráulico (Hydraulic Motor) (2 ci)
180 bar (2.611 PSI) @ 30 lpm (8 gpm)
Diâm. Cabo (Wire Rope Diameter): 11 mm (7/16")

	TRAÇÃO LINE PULL		VEL. LINHA LINE SPEED	
	KGF	LBF	M/MIN.	FT/MIN.
1	2.375	5,236	12,0	39.3
2	2.115	4,663	13,5	44.2
3	1.906	4,202	14,9	49.0
4	1.735	3,825	16,4	53.8

ARMAZENAMENTO STORAGE CAPACITY:

CABO (ROPE) Ø: 8~11 mm

TAMBORES DRUMS	A
CAMADAS LAYERS	5~4
QUANTIDADE LENGTH	80~48m (263~159ft)

CÓDIGO (CODE EXPLANATION):

GHL 2025 - A - 33 / OR12

GHL	GUINCHO HIDR. DE LEVANTAM. (HYDRAULIC HOIST WINCH)
2025	SÉRIE (SERIE)
A	MODELO TAMBOR (DRUM MODEL)
33	REDUÇÃO TOTAL (OVERALL GEAR RATIO)
OR12	MODELO MOTOR (MOTOR MODEL)

Copyright 2023 - ENQUIP
All Rights Reserved





Visite (Visit):
www.enquip.com.br

**ENQUIP**[®]

ENQUIP - Engenharia e Equipamentos Hidráulicos e Mecânicos Ltda.
Rua Cel. Laudemiro das Mercês Ferreira, 194 - Loteamento São João
Nova Friburgo / RJ - Brasil
CEP: 28605-250

Telefone (Phone): (22) 2522-0155 / E-mail: enquip@enquip.com.br
Celular (Mobile): (22) 9.8812-4850
www.enquip.com.br